

## 41 Matrix Key Multi-Function Piano with a Memory

### Features

- Operating voltage: 2.4V~5V
- System operating frequency: 512KHz
- 12 × 7 matrix input keys
- Auto power-off
- Power ON/OFF toggle input
- 41 tones, tone area: G2~B5
- 8 rhythms
- 8 timbres
- 16 steps of tempo speed
- 4 pulsatile sounds
- 12 demo songs
- Memory function with 62 notes
- 40 pin dual-in-line package

### General Description

The HT3421A is a 41-key musical instrument LSI implemented in the CMOS technology. The chip provides 8 rhythms, 8 timbres, 4 pulsatile sounds, 12 demo songs, and a 62-note memory storage function. The 12 × 7 matrix control keys of the HT3421A control both basic keys and function selection inputs.

In the Memory mode, the chip can store a tone of 62 notes. Pressing of the Replay key plays the stored songs, or pressing of OKP1 or OKP2 plays the stored songs tone by tone.

In the Demo mode, one of the 12 demo songs can be played. The timbre of the demo song can also be altered according to the instrument chosen.

### Pin Assignment

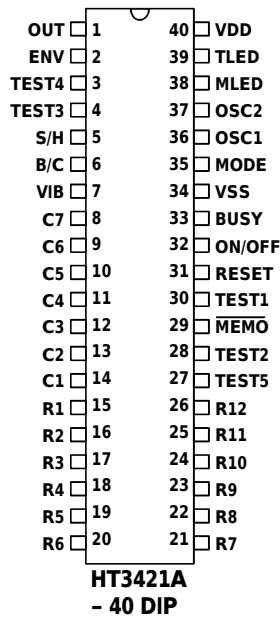

Block Diagram

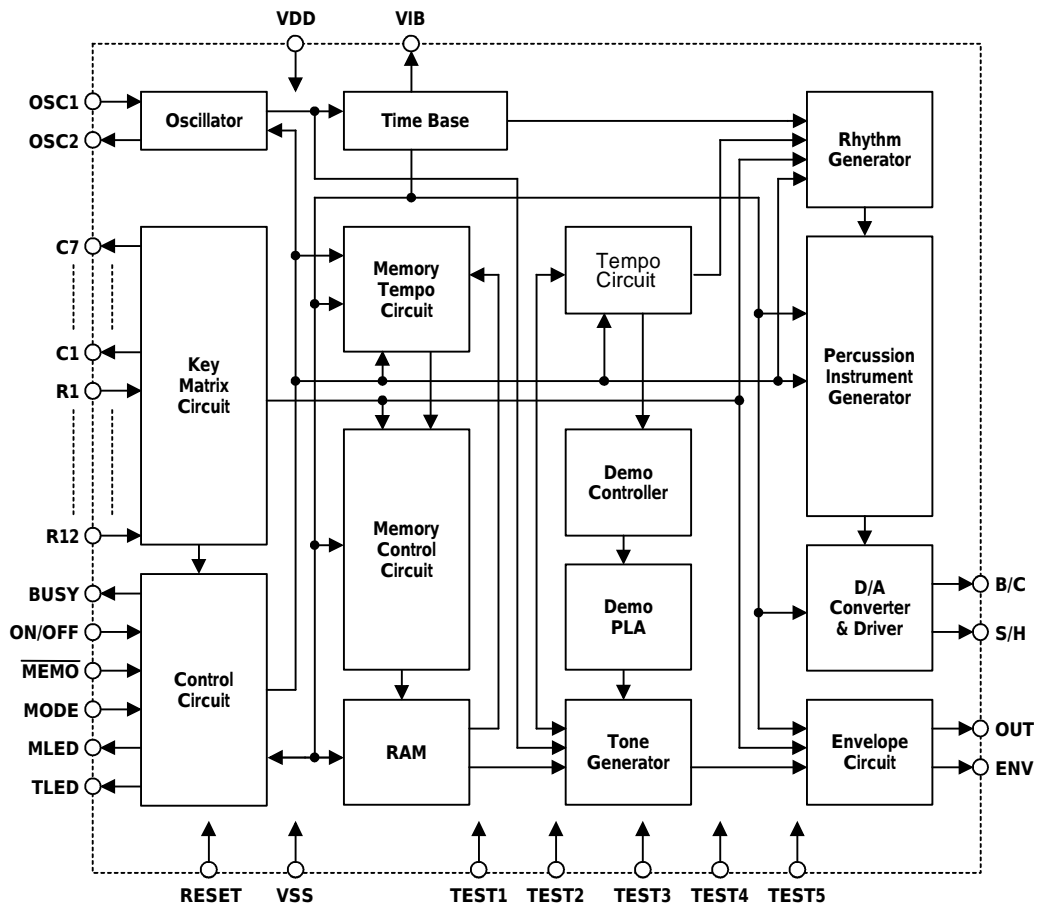

Pad Assignment

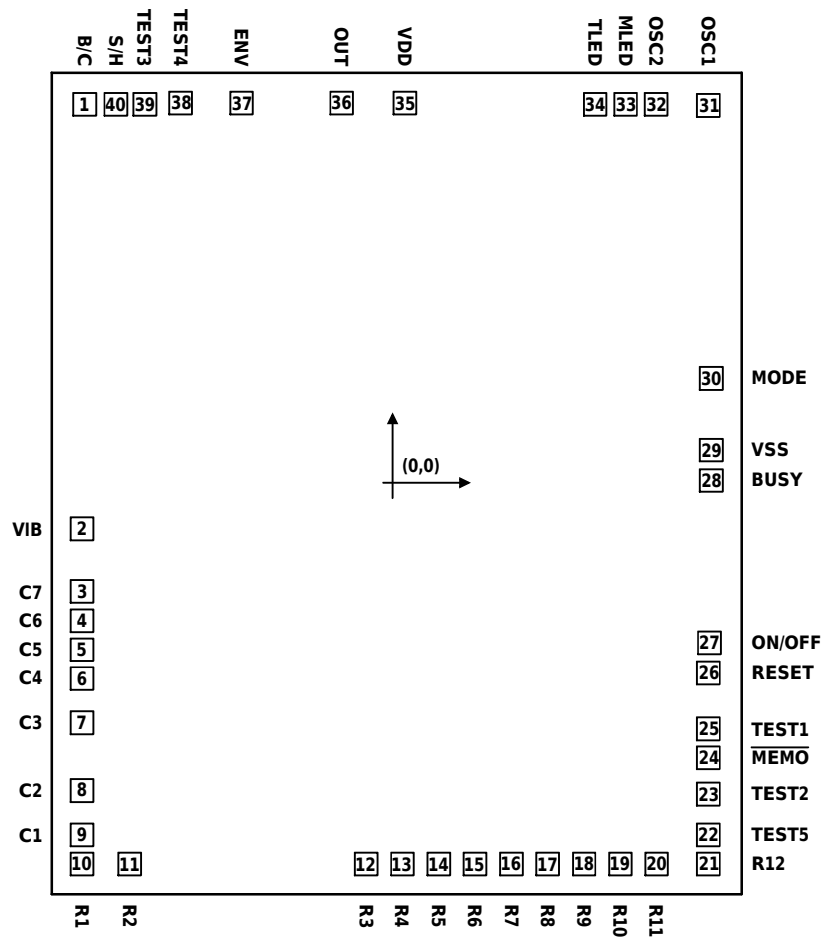

Chip size:  $179 \times 214 \text{ (mil)}^2$

\* The IC substrate should be connected to VDD in the PCB layout artwork.

**Pad Coordinates**

Unit: mil

Pad No.	X	Y	Pad No.	X	Y
1	-82.17	100.34	21	82.85	-100.60
2	-82.90	-11.99	22	82.85	-92.95
3	-82.90	-28.56	23	82.85	-82.24
4	-82.90	-36.38	24	82.85	-72.55
5	-82.90	-44.03	25	82.85	-64.90
6	-82.90	-51.64	26	82.85	-50.11
7	-82.90	-63.33	27	83.19	-42.20
8	-82.90	-81.26	28	83.70	0.81
9	-82.90	-92.95	29	83.70	8.80
10	-82.90	-100.60	30	83.70	27.84
11	-70.32	-100.60	31	82.85	100.00
12	-7.67	-100.60	32	69.08	100.34
13	1.93	-100.60	33	61.01	100.34
14	11.54	-100.60	34	52.93	100.34
15	21.14	-100.60	35	2.61	100.68
16	30.75	-100.60	36	-14.22	100.68
17	40.35	-100.60	37	-40.65	100.68
18	50.00	-100.60	38	-56.80	100.68
19	59.56	-100.60	39	-66.24	100.34
20	69.17	-100.60	40	-73.97	100.34

**Pin Description**

Pin No.	Pin Name	I/O	Internal Connection	Description
1	OUT	O	Transmission Gate	Tone output
2	ENV	O	CMOS	Envelope effect output
3	TEST4	—	—	For IC test only
4	TEST3	—	—	For IC test only
5	S/H	O	PMOS Open Drain	Snare-Drum or Hi-Hat pulsatile sound output
6	B/C	O	PMOS Open Drain	Bass-Drum or Cow-Bell pulsatile sound output
7	VIB	O	CMOS	Vibrato ON: VIB provides a 4Hz signal output. Vibrato OFF: VIB is a low-level output.
8~14	C7~C1	O	NMOS Open Drain	Matrix control key scanning outputs

Pin No.	Pin Name	I/O	Internal Connection	Description
15~26	R1~R12	I	CMOS Pull-High	Matrix control key scanning inputs
27	TEST5	—	—	For IC test only
28	TEST2	—	—	For IC test only
29	$\overline{\text{MEMO}}$	I	CMOS Pull-High	Connect this pin to VSS/VDD to work in either the memory or play mode.
30	TEST1	—	—	For IC test only
31	RESET	I	CMOS Pull-High	Power on reset
32	ON/OFF	I	CMOS Pull-High	At power on, the system is in the OFF state. Press the ON/OFF key to alternate the system from OFF to ON or vice versa. When power is auto off, there will be no tone output for 5 minutes.
33	BUSY	O	CMOS	BUSY is high while the system is operating, but low when the system is in the stand-by state.
34	VSS	I	—	Power supply (ground)
35	MODE	I	CMOS Pull-High	Toggle selection of play mode or memory mode The system is in the play mode at power-on.
36	OSC1	I	—	Oscillator input
37	OSC2	O	—	Oscillator output
38	MLED	O	NMOS Open Drain	Memory mode indication output
39	TLED	O	NMOS Open Drain	Tempo indication output
40	VDD	I	—	Power supply (positive)

### Absolute Maximum Ratings

Supply Voltage ..... -0.3V to 5.5V      Storage Temperature..... -50°C to 120°C  
 Input Voltage.....  $V_{SS}-0.3V$  to  $V_{DD}+0.3V$       Operating Temperature..... 0°C to 70°C

**Electrical Characteristics**

(Ta=25°C)

Symbol	Parameter	Test Condition		Min.	Typ.	Max.	Unit
		V <sub>DD</sub>	Condition				
V <sub>DD</sub>	Operating Voltage	—	—	2.4	4.5	5	V
I <sub>STB</sub>	Stand-by Current	4.5V	—	—	5	10	μA
I <sub>DD</sub>	Operating Current	4.5V	No load	—	0.3	1	mA
I <sub>OL1</sub>	Tone Output Sink Current	4.5V	V <sub>OL</sub> =0.45V	2.6	4.4	—	mA
I <sub>OL2</sub>	Envelop Output Sink Current	4.5V	V <sub>OL</sub> =0.45V	5	8.6	—	mA
I <sub>OH1</sub>	S/H (B/C) Output Source Current	4.5V	V <sub>OH</sub> =4V	-1.2	-1.8	—	mA
I <sub>OH2</sub>	Vibrato Output Source Current	4.5V	V <sub>OH</sub> =4V	-0.6	-1	—	mA
I <sub>OL3</sub>	C1~C7 Output Sink Current	4.5V	V <sub>OL</sub> =0.45V	1.8	3.0	—	mA
I <sub>IL</sub>	R1~R12 Input Low Current	4.5V	V <sub>IL</sub> =0.45V	-0.12	-0.2	—	mA
I <sub>OH3</sub>	BUSY Output Source Current	4.5V	V <sub>OH</sub> =4V	-1.8	-3	—	mA
I <sub>OL4</sub>	MLED Output Sink Current	4.5V	V <sub>OL</sub> =0.45V	1.2	2.0	—	mA
I <sub>OL5</sub>	TLED Output Sink Current	4.5V	V <sub>OL</sub> =0.45V	1	1.8	—	mA
V <sub>IL</sub>	“L” Input Voltage	—	—	—	—	0.2V <sub>DD</sub>	V
V <sub>IH</sub>	“H” Input Voltage	—	—	0.7V <sub>DD</sub>	—	—	V
F <sub>OSC</sub>	System Frequency	4.5V	R <sub>OSC</sub> =48KΩ	—	512	—	KHz

**Functional Description**
**Matrix control key position & description**

	C1	C2	C3	C4	C5	C6	C7
<b>R1</b>	K31	K19	K7	Bass	Tmp up	Tim1	Rhm1
<b>R2</b>	K32	K20	K8	Bell	Tmp down	Tim2	Rhm2
<b>R3</b>	K33	K21	K9	Snare	Rhm ON	Tim3	Rhm3
<b>R4</b>	K34	K22	K10	Hat	Rhm	Tim4	Rhm4
<b>R5</b>	K35	K23	K11	—	Rhm OFF	Tim5	Rhm5
<b>R6</b>	K36	K24	K12	—	Demo	Tim6	Rhm6
<b>R7</b>	K37	K25	K13	K1	Vib	Tim7	Rhm7
<b>R8</b>	K38	K26	K14	K2	Sust	Tim8	Rhm8
<b>R9</b>	K39	K27	K15	K3	Memo clear	—	—
<b>R10</b>	K40	K28	K16	K4	Replay	—	—
<b>R11</b>	K41	K29	K17	K5	OKP1	—	—
<b>R12</b>	—	K30	K18	K6	OKP2	—	—

<b>Key Name</b>	<b>Description</b>
K1~K41	Scale from G2 to B5 There is a half-pitch variation among K1~K41. If a key is pressed and held and the other key is pressed as well, the later tone will replace the former tone. Refer to item 2 for the contrast keyboard position.
Bass	Bass drum sound select input Pressing this key adds a single note bass drum sound.
Bell	Cow bell sound select input Pressing this key adds a single note bell sound.
Snare	Snare drum sound select input Pressing this key adds a single note snare drum sound.
Hat	Hi-Hat sound select input Pressing this key adds a single note hi-hat sound.
Tmp up	16-level tempo speed selection Set to level 8 at power-on Tempo will speed up while pressing this key until the maximal speed is reached.
Tmp down	Pressing this key lowers the tempo speed until the minimum speed is reached.
Rhm ON	Rhythm enabled Set to OFF at power-on
Rhm	Rhythm enable/disable toggle selection
Rhm OFF	Rhythm disabled
Demo	Selection of demo song playing One of the provided 12 demo songs can be chosen by pressing the corresponding key (see section 3 for details). If no key is pressed the first song will be chosen instead.
Vib	Vibrato effect ON/OFF toggle selection Set to OFF at power-on
Sust	Sustain effect ON/OFF toggle selection Set to ON at power-on
Memo clear	Clear the contents of the memory Used only in the Memory mode
Replay	Press this key to re-play the song (in memory).
OKP1, OKP2	This key functions as a Replay function, but it plays only one tone.
Tim1~Tim8	Timbre selection It is set to Tim1 at power-on (refer to 4 for the instrument names).
Rhm1~Rhm8	Rhythm selection It is set to Rhm1 at power-on (refer to 5 for the rhythm names).

K1~K41 and their corresponding keyboard tone outputs are as shown:

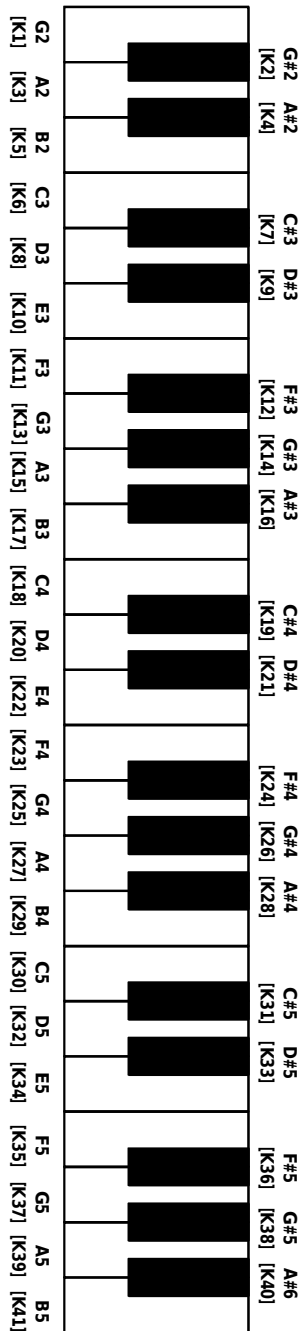

**Demo songs and corresponding keys**

First, press the Demo key to enter the Demo mode, and then press a key to select a song.

No.	Select Key	Demo Song Name
1	K18	American Patrol
2	K20	It Is a Small World
3	K22	Old Macdonald Had a Farm
4	K23	Yankee Doodle
5	K25	This Old Man
6	K27	Wooden Heart
7	K29	Happy Birthday to You
8	K30	Silent Night
9	K32	Home Sweet Home
10	K34	Symphony No. 9
11	K35	Mary Had a Little Lamb
12	K37	Twinkle Twinkle Little Star

While the demo song is playing, other “Select keys” can be pressed to alter the song.

The timbre of the demo song can be changed by pressing Tim1~Tim8. Pulsatile sounds can be added by pressing the Bass, Bell, Snare, or Hat input.

During the playing of a song, pressing the demo song key will terminate the output.

The following is a list of the 8-instrument timbre:

Key	Instrument
Tim1	Piano
Tim2	Oboe
Tim3	Ukulele
Tim4	Flute
Tim5	Trumpet
Tim6	Saxophone
Tim7	Music Box
Tim8	Church Bell



The 8-rhythm list is as shown:

<b>Key</b>	<b>Rhythm</b>
Rhm1	Chacha
Rhm2	March
Rhm3	Rock
Rhm4	Swing
Rhm5	8 Beat
Rhm6	Beguine
Rhm7	Ballad
Rhm8	Waltz

**Memory mode**

The system enters the memory mode by using either the MEMO or MODE switch. The indicator LED will also indicate the system is in the memory mode. This toggle action MODE switch is effective only if the MEMO switch is connected to VDD or left open. The MEMO switch has an overriding effect and functions irrespective of the condition of the MODE switch.

<b>MEMO</b>	<b>Action</b>
VDD or Open	Initially in the play mode but MODE switch can toggle between play/memory
VSS	In the memory mode only, and MODE switch has no effect

In the memory mode, each sequential pressing of K1~K41 (G2~B5) will be stored, except the rhythm and pulsatile sounds. Pressing of the Memo clear key will erase the contents of the memory.

In either the play or memory mode, the stored song can be played by pressing the Replay key or the stored song is played tone by tone by pressing OKP1 or OKP2.

While in the memory mode, the demo song can be played by pressing the Demo key. Once the demo mode is quit, the system will return to the memory mode.

Application Circuit

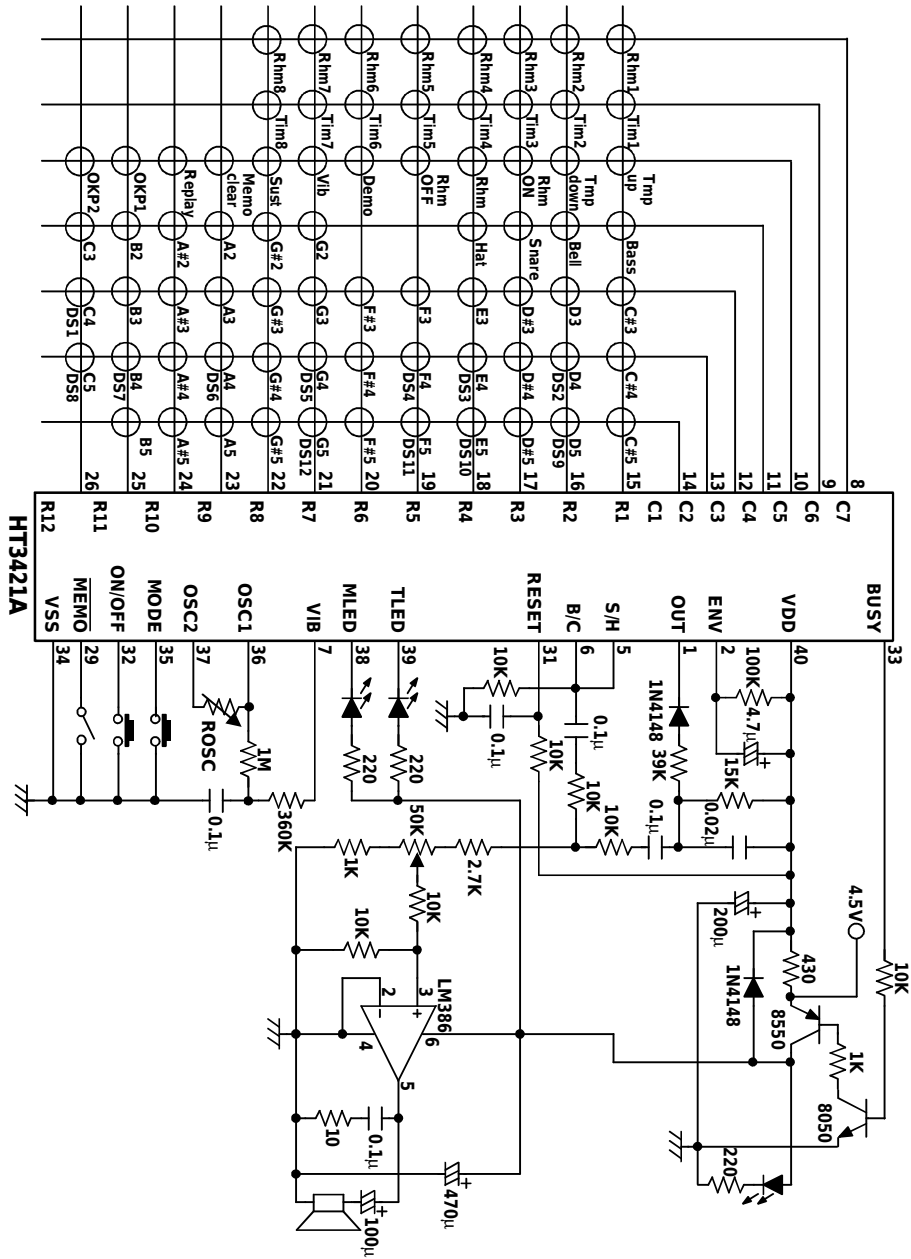

Dsn: Demo Song No1 ~ No12.  
 \*Note: Vary Rosc to obtain 512KHz system frequency [Rosc ≐ 48K].